INSTALLATION INSTRUCTIONS

WALL MOUNTED PACKAGE HEAT PUMPS

MODELS

W18H1

W24H1

W30H1

W36H1

W42H1

W48H1

W60H1

W24H1D

W30H1D

W36H1D

W42H1D

W48H1D

W60H1D



Bard Manufacturing Company, Inc.
Bryan, Ohio 43506

Since 1914...Moving ahead just as planned.

Manual: 2100-511F
Supersedes: 2100-511E
File: Volume III Tab 17
Date: 02-17-12

Contents

Getting Other Information and Publications 3

Wall Mount General Information

Wall Mount Model Nomenclature	4
Shipping Damage	4
General	4
Duct Work	5
Filters	5
Fresh Air Intake	5
Condensate Drain	5

Installation Instructions

Wall Mounting Information	6
Mounting the Unit	6
Clearances Required	6
Minimum Clearances	6
Wiring – Main Power	14
Wiring – Low Voltage Wiring	14

Figures

Figure 1 Fresh Air Damper Assembly	5
Figure 2 Unit Dimensions	7
Figure 3A Mounting Instructions	8
Figure 3B Mounting Instructions - W18, W24, W30, W36	9
Figure 3C Mounting Instructions - W42, W48, W60	10
Figure 4 Electric Heat Clearance	11
Figure 5 Wall Mounting Instructions	12
Figure 6 Wall Mounting Instructions	12
Figure 7 Common Wall Mounting Installations	13
Figure 8 Defrost Control Board	18
Figure 9 Fan Blade Setting	21

Start Up

General	15
Topping Off System Charge	15
Safety Practices	15
Important Installer Note	16
Wall Mounted Air Conditioner	16
Three Phase Scroll Compressor	16
Phase Monitor	16
Condenser Fan Operation	16
Service Hints	16
Sequence of Operation	17
Pressure Service Ports	17
Defrost Cycle	17

Troubleshooting

Solid State Heat Pump Control	19
Checking Temperature Sensor	20
Fan Blade Setting Dimensions	21
Removal of Fan Shroud	21
Refrigerant Charge	21

Tables

Table 1 Troubleshooting	19
Table 2 Fan Blade Dimension	21
Table 3A Cooling Pressure	22
Table 3B Heating Pressure	22
Table 4 Electrical Specifications W**H	23
Table 5 Recommended Airflow	24
Table 6 Indoor Blower Performance	24
Tables 7 Maximum ESP Electric Heat Only	25
Table 8 Electric Heat	25
Table 9 Optional Accessories	26
Table 10 Vent & Control Options	27

GETTING OTHER INFORMATION AND PUBLICATIONS

These publications can help you install the air conditioner or heat pump. You can usually find these at your local library or purchase them directly from the publisher. Be sure to consult current edition of each standard.

National Electrical Code ANSI/NFPA 70

Standard for the Installation ANSI/NFPA 90A
of Air Conditioning and Ventilating Systems

Standard for Warm Air ANSI/NFPA 90B
Heating and Air Conditioning Systems

Load Calculation for ACCA Manual J
Residential Winter and Summer Air Conditioning

Duct Design for Residential ACCA Manual D
Winter and Summer Air Conditioning and Equipment
Selection

FOR MORE INFORMATION, CONTACT THESE PUBLISHERS:

ACCA **Air Conditioning Contractors of America**
1712 New Hampshire Ave. N.W.
Washington, DC 20009
Telephone: (202) 483-9370
Fax: (202) 234-4721

ANSI **American National Standards Institute**
11 West Street, 13th Floor
New York, NY 10036
Telephone: (212) 642-4900
Fax: (212) 302-1286

ASHRAE **American Society of Heating, Refrigeration
and Air Conditioning Engineers, Inc.**
1791 Tullie Circle, N.E.
Atlanta, GA 30329-2305
Telephone: (404) 636-8400
Fax: (404) 321-5478

NFPA **National Fire Protection Association**
Batterymarch Park
P.O. Box 9101
Quincy, MA 02269-9901
Telephone: (800) 344-3555
Fax: (617) 984-7057

WALL MOUNT GENERAL INFORMATION

HEAT PUMP WALL MOUNT MODEL NOMENCLATURE

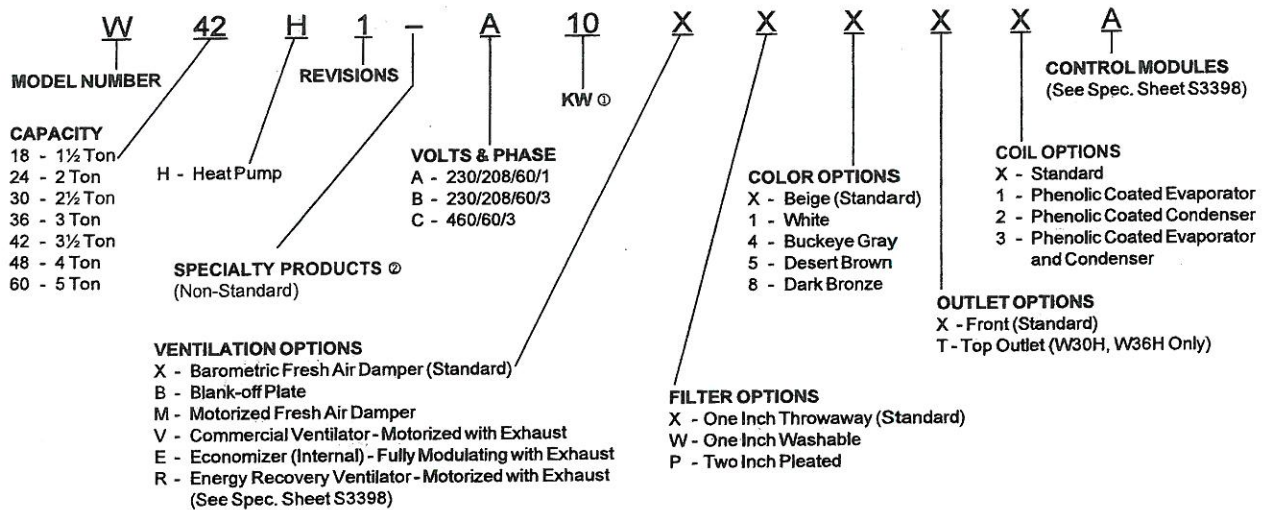

Ⓞ For 0 KW and circuit breakers (230/208 volt) or toggle disconnect (460V) applications, insert 0Z in the KW field of the model number.

Ⓞ Insert "D" for dehumidification with hot gas reheat. Reference Form 7960-576 for complete details.

NOTE: Vent options X, B and M are without exhaust capability. May require separate field supplied barometric relief in building.

SHIPPING DAMAGE

Upon receipt of equipment, the carton should be checked for external signs of shipping damage. If damage is found, the receiving party must contact the last carrier immediately, preferably in writing, requesting inspection by the carrier's agent.

GENERAL

The equipment covered in this manual is to be installed by trained, experienced service and installation technicians.

The refrigerant system is completely assembled and charged. All internal wiring is complete.

The unit is designed for use with or without duct work. Flanges are provided for attaching the supply and return ducts.

These instructions explain the recommended method to install the air cooled self-contained unit and the electrical wiring connections to the unit.

These instructions and any instructions packaged with any separate equipment required to make up the entire air conditioning system should be carefully read before beginning the installation. Note particularly "Starting Procedure" and any tags and/or labels attached to the equipment.

While these instructions are intended as a general recommended guide, they do not supersede any national and/or local codes in any way. Authorities having jurisdiction should be consulted before the installation is made. See Page 3 for information on codes and standards.

Size of unit for a proposed installation should be based on heat loss/gain calculation made according to methods of Air Conditioning Contractors of America (ACCA). The air duct should be installed in accordance with the Standards of the National Fire Protection Association for the Installation of Air Conditioning and Ventilating Systems of Other Than Residence Type, NFPA No. 90A, and Residence Type Warm Air Heating and Air Conditioning Systems, NFPA No. 90B. Where local regulations are at a variance with instructions, installer should adhere to local codes.

DUCT WORK

All duct work, supply and return, must be properly sized for the design airflow requirement of the equipment. Air Conditioning Contractors of America (ACCA) is an excellent guide to proper sizing. All duct work or portions thereof not in the conditioned space should be properly insulated in order to both conserve energy and prevent condensation or moisture damage.

Refer to Maximum ESP of operation Electric Heat Tables 7.

Design the duct work according to methods given by the Air Conditioning Contractors of America (ACCA). When duct runs through unheated spaces, it should be insulated with a minimum of one inch of insulation. Use insulation with a vapor barrier on the outside of the insulation. Flexible joints should be used to connect the duct work to the equipment in order to keep the noise transmission to a minimum.

Models W18 & W24 are approved for zero inch clearance to the supply duct. For model series W30, W36, W42, W48 and W60 a 1/4 inch clearance to combustible material for the first three feet of duct attached to the outlet air frame is required. See Wall Mounting Instructions and Figures 3 and 4 for further details.

Ducts through the walls must be insulated and all joints taped or sealed to prevent air or moisture entering the wall cavity.

Some installations may not require any return air duct. A metallic return air grille is required with installations not requiring a return air duct. The spacing between louvers on the grille shall not be larger than 5/8 inch.

Any grille that meets with 5/8 inch louver criteria may be used. It is recommended that Bard Return Air Grille Kit RG2 through RG5 or RFG2 through RFG5 be installed when no return duct is used. Contact distributor or factory for ordering information. If using a return air filter grille, filters must be of sufficient size to allow a maximum velocity of 400 fpm.

NOTE: *If no return air duct is used, applicable installation codes may limit this cabinet to installation only in a single story structure.*

FILTERS

A 1-inch throwaway filter is standard with each unit. The filter slides into position making it easy to service. This filter can be serviced from the outside by removing the filter access panel. A 1-inch washable filter and 2-inch pleated filter are also available as optional accessories. The internal filter brackets are adjustable to accommodate the 2-inch filter by bending two (2) tabs down on each side of the filter support bracket.

FRESH AIR INTAKE

All units are built with fresh air inlet slots punched in the service door.

If the unit is equipped with a fresh air damper assembly, the assembly is shipped already attached to the unit. The damper blade is locked in the closed position. To allow the damper to operate, the maximum and minimum blade position stops must be installed. See Figure 1.

All capacity, efficiency and cost of operation information is based upon the fresh air blank-off plate in place and is recommended for maximum energy efficiency.

The blank-off plate is available upon request from the factory and is installed in place of the fresh air damper shipped with each unit.

CONDENSATE DRAIN

A plastic drain hose extends from the drain pan at the top of the unit down to the unit base. There are openings in the unit base for the drain hose to pass through. In the event the drain hose is connected to a drain system of some type, it must be an open or vented type system to assure proper drainage.

**FIGURE 1
FRESH AIR DAMPER**

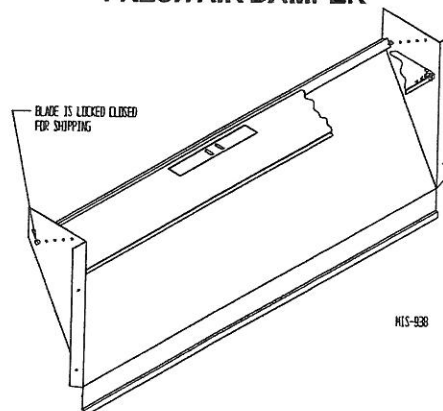

INSTALLATION INSTRUCTIONS

WALL MOUNTING INFORMATION

1. Two holes for the supply and return air openings must be cut through the wall as shown in Figure 3.
2. On wood frame walls, the wall construction must be strong and rigid enough to carry the weight of the unit without transmitting any unit vibration.
3. Concrete block walls must be thoroughly inspected to insure that they are capable of carrying the weight of the installed unit.

MOUNTING THE UNIT

1. These units are secured by wall mounting brackets which secure the unit to the outside wall surface at both sides. A bottom mounting bracket, attached to skid for shipping, is provided for ease of installation, but is not required.
2. The unit itself is suitable for 0 inch clearance, but the supply air duct flange and the first 3 feet of supply air duct require a minimum of 1/4 inch clearance to combustible material for model series W30, W36, W42, W48 and W60. However, it is generally recommended that a 1-inch clearance is used for ease of installation and maintaining the required clearance to combustible material. See Figure 3 for details on opening sizes.
3. Locate and mark lag bolt locations and bottom mounting bracket location. See Figure 3.
4. Mount bottom mounting bracket.
5. Hook top rain flashing, attached to front - right of supply flange for shipping, under back bend of top.



WARNING

Failure to provide the 1/4 inch clearance between the supply duct and a combustible surface for the first 3 feet of duct can result in fire causing damage, injury or death.

6. Position unit in opening and secure with 5/16 lag bolts; use 7/8 inch diameter flat washers on the lag bolts.
7. Secure rain flashing to wall and caulk across entire length of top. See Figure 3.
8. For additional mounting rigidity, the return air and supply air frames or collars can be drilled and screwed or welded to the structural wall itself (depending upon wall construction). Be sure to observe required clearance if combustible wall.
9. On side-by-side installations, maintain a minimum of 20 inches clearance on right side to allow access to control panel and heat strips, and to allow proper airflow to the outdoor coil. Additional clearance may be required to meet local or national codes.

Clearances Required for Service Access and Adequate Condenser Airflow

MODELS	LEFT SIDE	RIGHT SIDE
W18H, W24H, W30H, W36H	15"	20"
W42H, W48H, W60H	20"	20"

Minimum Clearances Required to Combustible Materials

MODELS	SUPPLY AIR DUCT FIRST THREE FEET	CABINET
W18H / W24H	0"	0"
W30H / W36H	1/4"	0"
W42H / W48H / W60H	1/4"	0"

FIGURE 2

Dimensions of Basic Unit for Architectural and Installation Requirements (Nominal)

MODEL	WIDTH (W)	DEPTH (D)	HEIGHT (H)	SUPPLY				RETURN														
				A	B	C	B	E	F	G	I	J	K	L	M	N	O	P	Q	R	S	T
W18H1 W24H1	33.300	17.125	70.563	7.88	19.88	11.88	19.88	35.00	18.50	25.75	20.56	26.75	28.06	29.25	27.00	2.63	34.13	22.06	10.55	5.00	12.00	5.00
W30H1 W36H1	38.200	17.125	70.563	7.88	27.88	13.88	27.88	40.00	18.50	25.75	17.93	26.75	28.75	29.25	27.00	2.63	39.13	22.75	9.14	5.00	12.00	5.00
W42H1 W48H1	42.075	22.432	84.875	9.88	29.88	15.88	29.88	43.88	19.10	31.66	30.00	32.68	26.94	34.69	32.43	3.37	43.00	23.88	10.00	1.44	16.00	1.88
W60H1	42.075	22.432	94.875	9.88	29.88	15.88	29.88	43.88	13.56	41.66	30.00	42.68	36.94	44.69	42.43	3.37	43.00	33.88	10.00	1.44	16.00	1.88

All dimensions are in inches. Dimensional drawings are not to scale.

W**H
RIGHT
UNIT

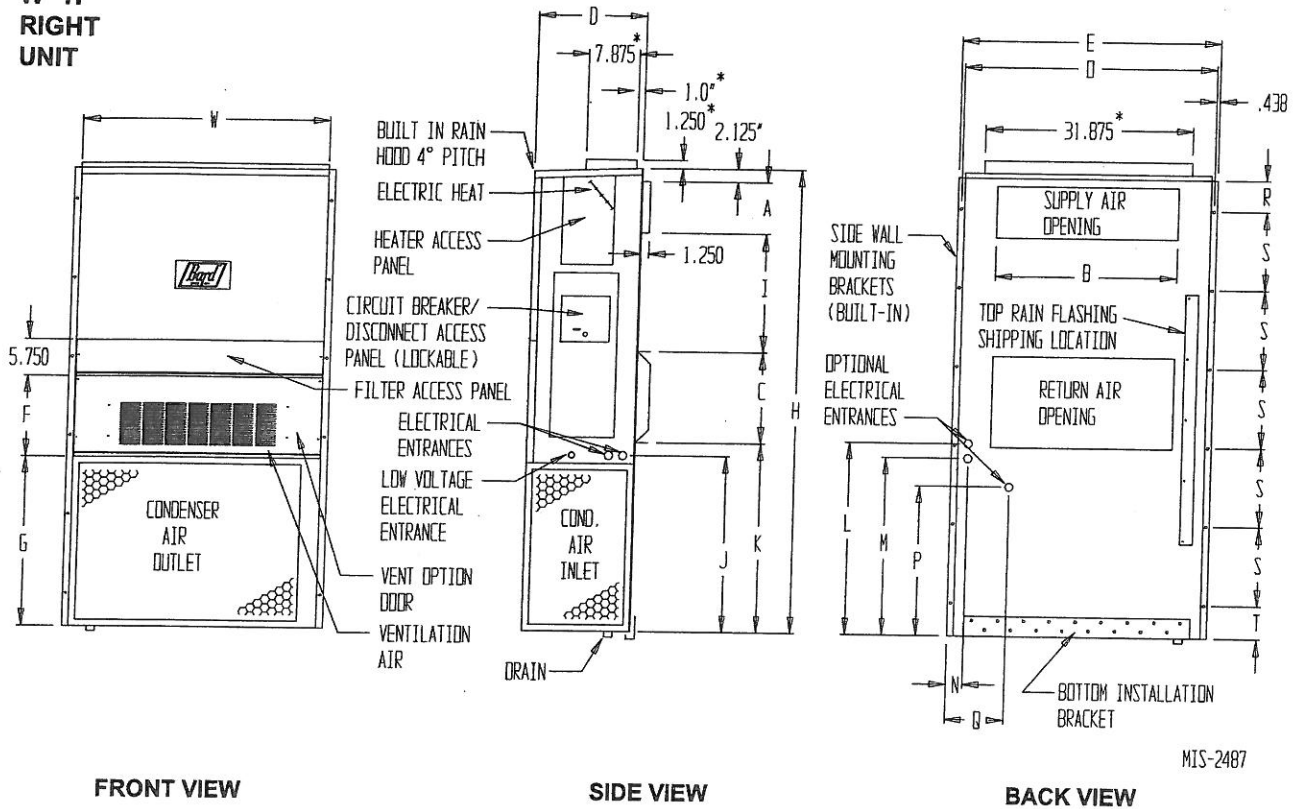

MIS-2487

*Optional top outlet (factory installed only) for W30H and W36H models only.

FIGURE 3A
W18H1, W24H1
MOUNTING INSTRUCTIONS

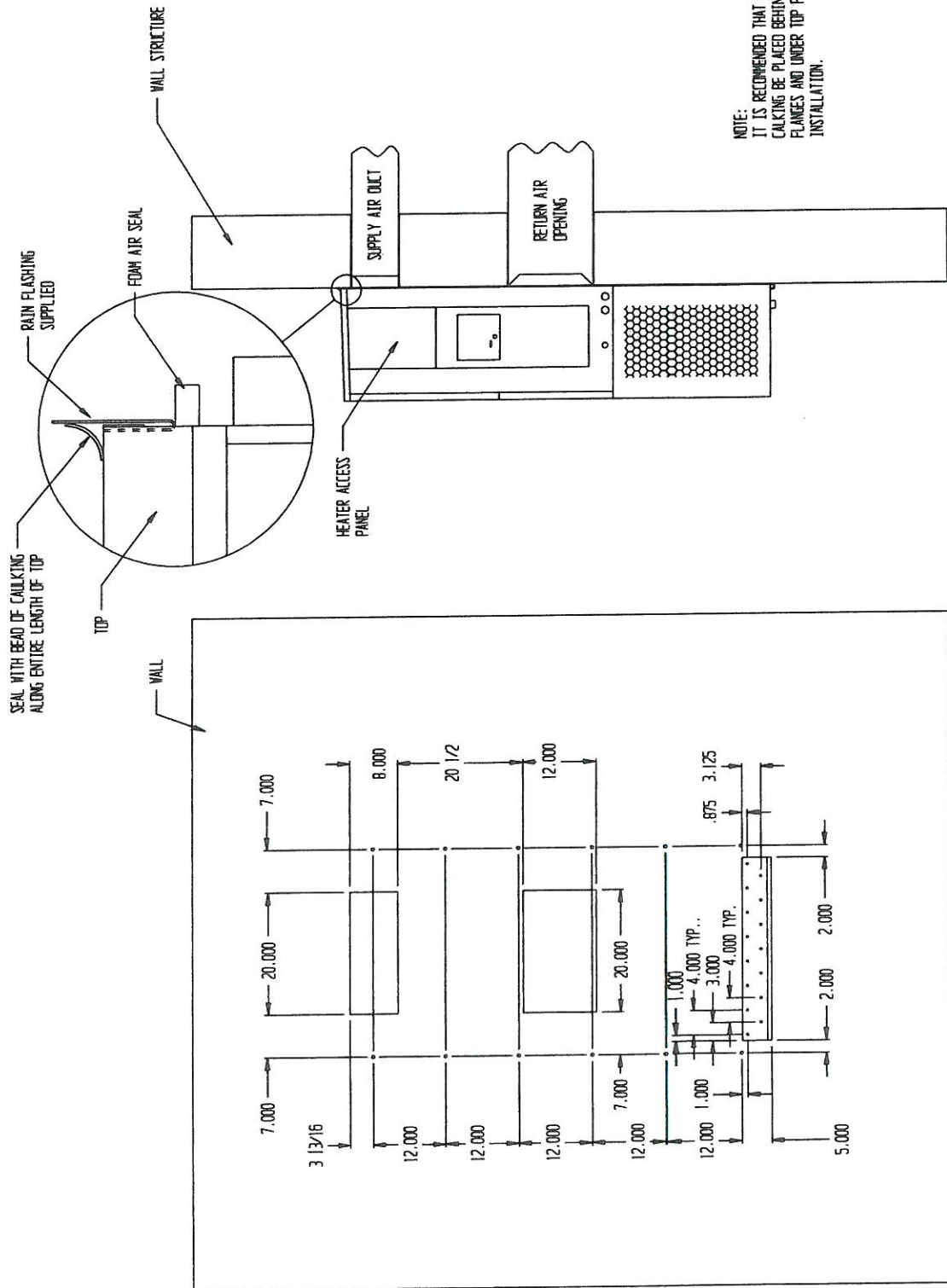

NOTE:
 IT IS RECOMMENDED THAT A BEAD OF SILICONE
 CAULKING BE PLACED BEHIND THE SIDE MOUNTING
 FLANGES AND UNDER TOP FLASHING AT TIME OF
 INSTALLATION.

FIGURE 3B
W30H1, W36H1
MOUNTING INSTRUCTIONS

	A	B	C	D	E
REQUIRED DIMENSIONS TO MAINTAIN 7/4" MIN. CLEARANCE FROM COMBUSTIBLE MATERIALS*	28 1/2	8 1/2	5 1/4	3 13/16	17 5/8
REQUIRED DIMENSIONS TO MAINTAIN RECOMMENDED 1" CLEARANCE FROM COMBUSTIBLE MATERIALS	30	10	4 1/2	4 9/16	16 7/8

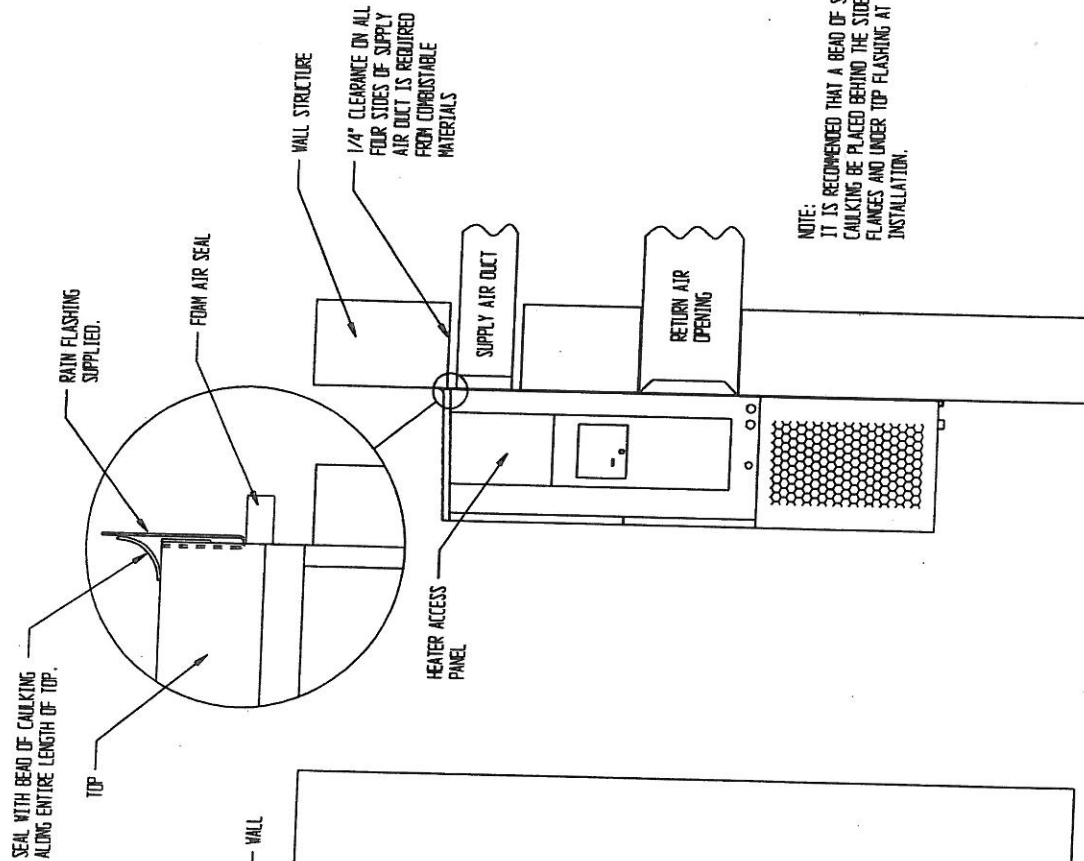

NOTE:
 IT IS RECOMMENDED THAT A BEAD OF SILICONE CAULKING BE PLACED BEHIND THE SIDE MOUNTING FLANGES AND UNDER TOP FLASHING AT TIME OF INSTALLATION.

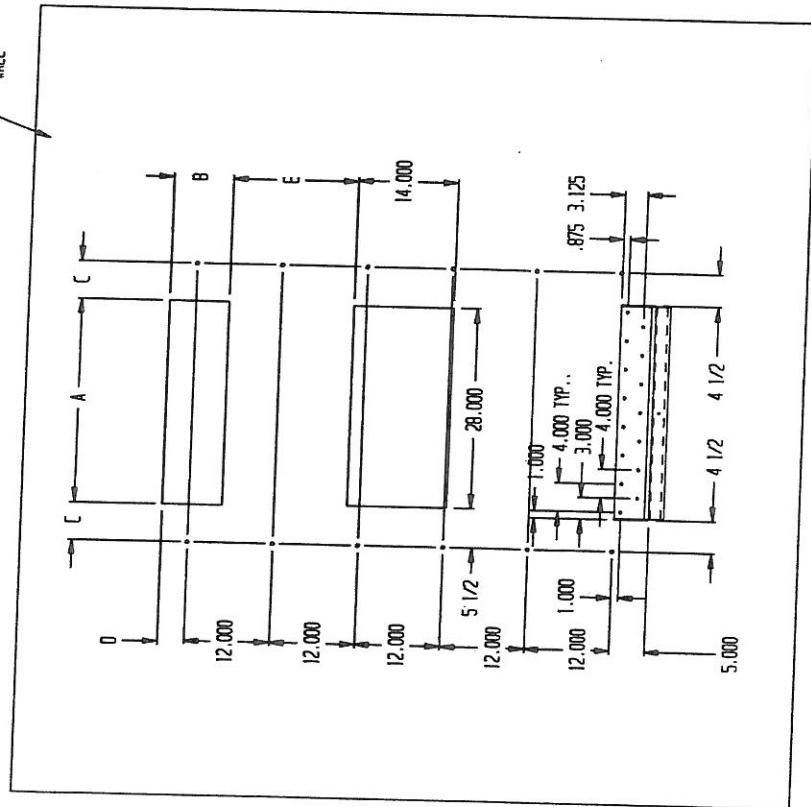

FIGURE 5 WALL MOUNTING INSTRUCTIONS

SEE FIGURE 3 – MOUNTING INSTRUCTIONS

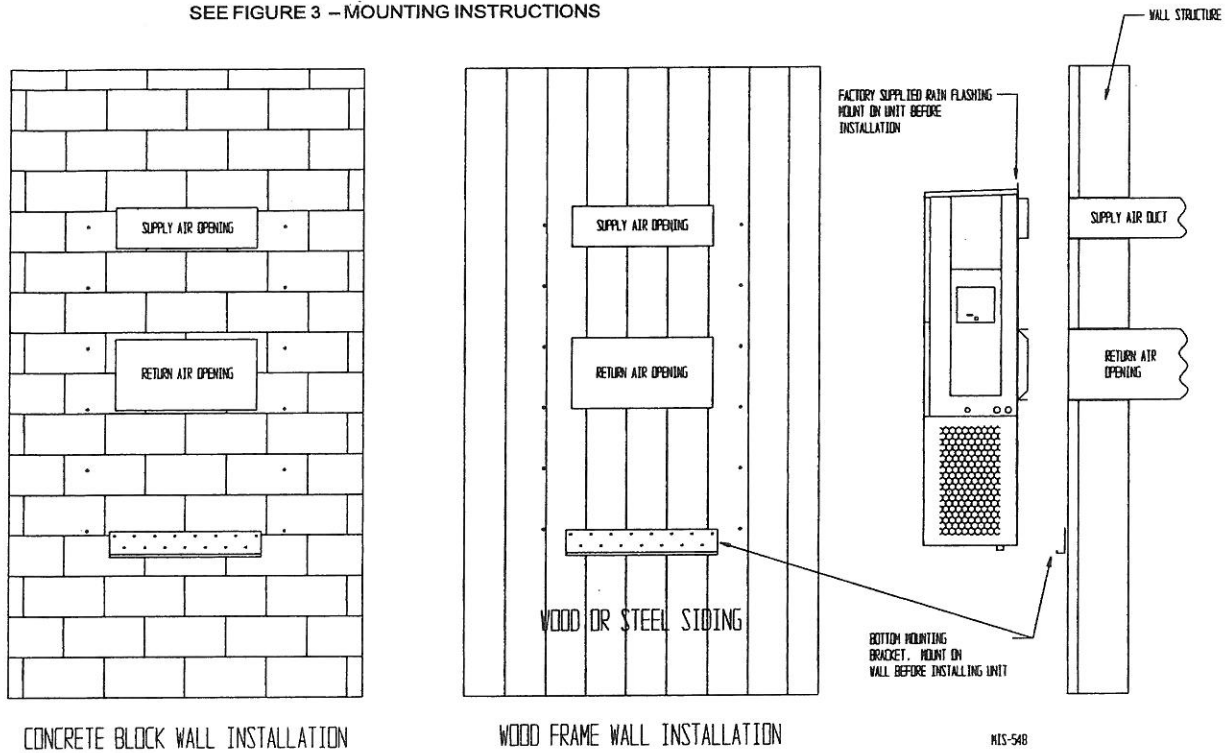
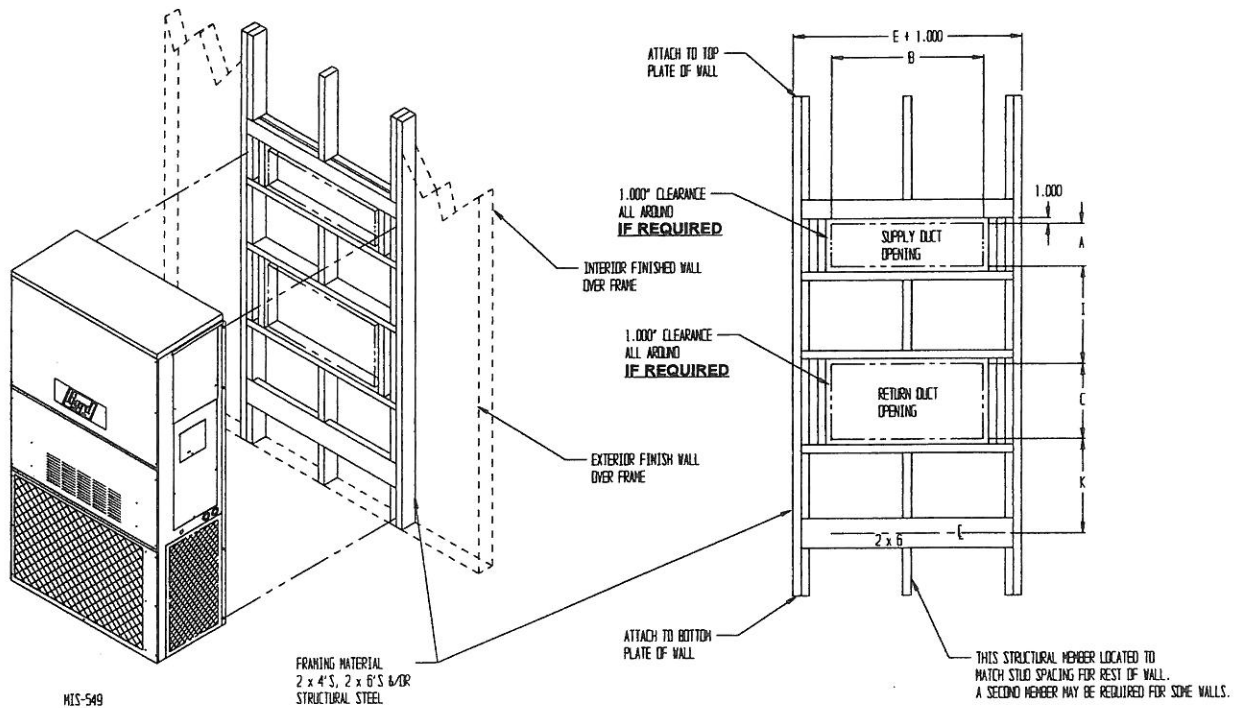
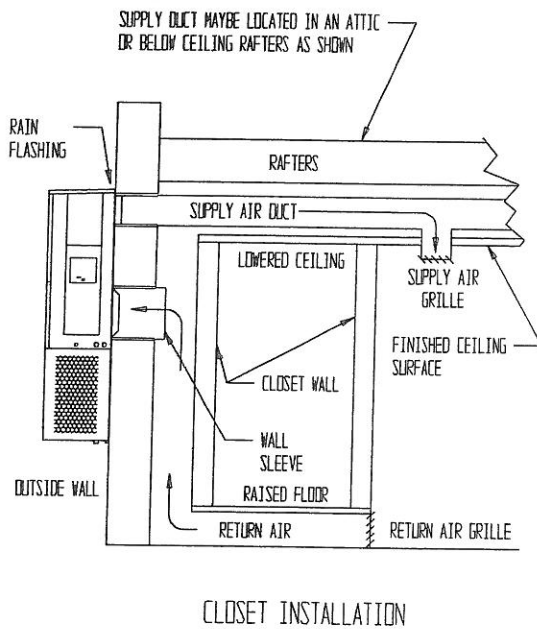
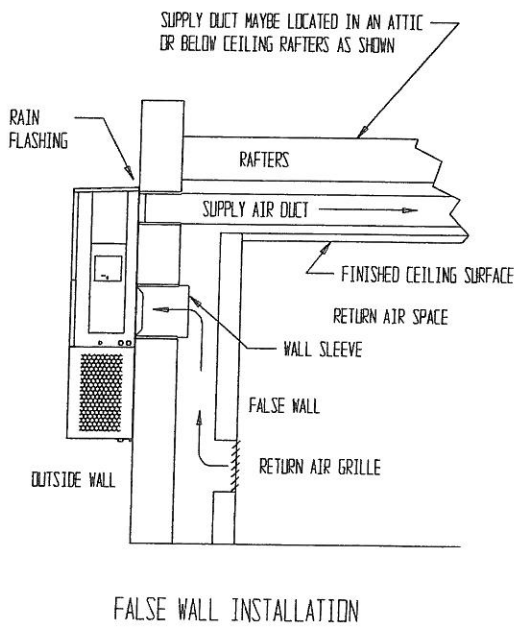
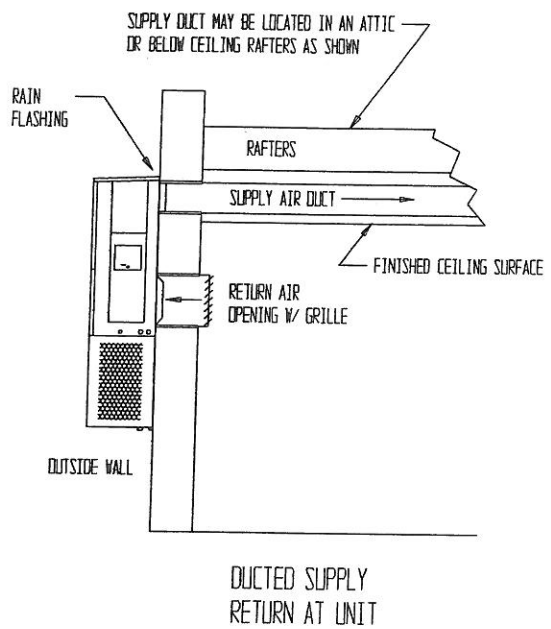
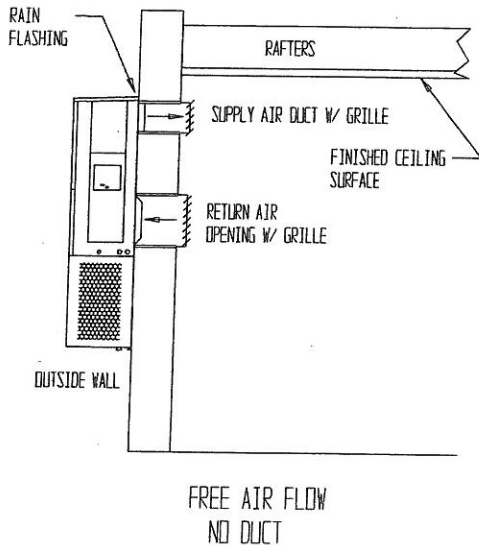

FIGURE 6 WALL MOUNTING INSTRUCTIONS

SEE UNIT DIMENSIONS, FIGURE 2,
FOR ACTUAL DIMENSIONS



**FIGURE 7
COMMON WALL MOUNTING INSTALLATIONS**



MIS-550 A

WIRING – MAIN POWER

Refer to the unit rating plate for wire sizing information and maximum fuse or “HACR” type circuit breaker size. Each outdoor unit is marked with a “Minimum Circuit Ampacity”. This means that the field wiring used must be sized to carry that amount of current.

Depending on the installed KW of electric heat, there may be two field power circuits required. If this is the case, the unit serial plate will so indicate. All models are suitable only for connection with copper wire. Each unit and/or wiring diagram will be marked “Use Copper Conductors Only”. These instructions *must be* adhered to. Refer to the National Electrical Code (NEC) for complete current carrying capacity data on the various insulation grades of wiring material. All wiring must conform to NEC and all local codes.

The electrical data lists fuse and wire sizes (75° C copper) for all models including the most commonly used heater sizes. Also shown are the number of field power circuits required for the various models with heaters.

The unit rating plate lists a “Maximum Time Delay Relay Fuse” or “HACR” type circuit breaker that is to be used with the equipment. The correct size must be used for proper circuit protection and also to assure that there will be no nuisance tripping due to the momentary high starting current of the compressor motor.

The disconnect access door on this unit may be locked to prevent unauthorized access to the disconnect. To convert for the locking capability, bend the tab located in the bottom left-hand corner of the disconnect opening under the disconnect access panel straight out. This tab will now line up with the slot in the door. When shut, a padlock may be placed through the hole in the tab preventing entry.

See “Start Up” section for important information on three phase scroll compressor start ups.

See Table 4 for Electrical Specifications.

WIRING – LOW VOLTAGE WIRING

230/208V, 1 phase and 3 phase equipment dual primary voltage transformers. All equipment leaves the factory wired on 240V tap. For 208V operation, reconnect from 240V to 208V tap. The acceptable operating voltage range for the 240 and 208V taps are:

TAP	RANGE
240	253 – 216
208	220 – 187

NOTE: The voltage should be measured at the field power connection point in the unit and while the unit is operating at full load (maximum amperage operating condition).

For wiring size and connections, refer to Wiring Manual 2100-516.

THESE UNITS REQUIRE R-410A REFRIGERANT AND POLYOL ESTER OIL.

GENERAL:

1. Use separate service equipment to avoid cross contamination of oil and refrigerants.
2. Use recovery equipment rated for R-410A refrigerant.
3. Use manifold gauges rated for R-410A (800 psi/250 psi low).
4. R-410A is a binary blend of HFC-32 and HFC-125.
5. R-410A is nearly azeotropic - similar to R-22 and R-12. Although nearly azeotropic, charge with liquid refrigerant.
6. R-410A operates at 40-70% higher pressure than R-22, and systems designed for R-22 cannot withstand this higher pressure.
7. R-410A has an ozone depletion potential of zero, but must be reclaimed due to its global warming potential.
8. R-410A compressors use Polyol Ester oil.
9. Polyol Ester oil is hygroscopic; it will rapidly absorb moisture and strongly hold this moisture in the oil.
10. A liquid line dryer must be used - even a deep vacuum will not separate moisture from the oil.
11. Limit atmospheric exposure to 15 minutes.
12. If compressor removal is necessary, always plug compressor immediately after removal. Purge with small amount of nitrogen when inserting plugs.

TOPPING OFF SYSTEM CHARGE

If a leak has occurred in the system, Bard Manufacturing recommends reclaiming, evacuating (see criteria above), and charging to the nameplate charge. If done correctly, topping off the system charge can be done without problems.

With R-410A, there are no significant changes in the refrigerant composition during multiple leaks and recharges. R-410A refrigerant is close to being an azeotropic blend (it behaves like a pure compound or single component refrigerant). The remaining refrigerant charge, in the system, may be used after leaks have occurred and then "top-off" the charge by utilizing the pressure charts on the inner control panel cover as a guideline.

REMEMBER: When adding R-410A refrigerant, it must come out of the charging cylinder/tank as a liquid to avoid any fractionation, and to insure optimal system performance. Refer to instructions for the cylinder that is being utilized for proper method of liquid extraction.



WARNING

Failure to conform to these practices could lead to damage, injury or death.

SAFETY PRACTICES:

1. Never mix R-410A with other refrigerants.
2. Use gloves and safety glasses, Polyol Ester oils can be irritating to the skin, and liquid refrigerant will freeze the skin.
3. Never use air and R-410A to leak check; the mixture may become flammable.
4. Do not inhale R-410A – the vapor attacks the nervous system, creating dizziness, loss of coordination and slurred speech. Cardiac irregularities, unconsciousness and ultimate death can result from breathing this concentration.
5. Do not burn R-410A. This decomposition produces hazardous vapors. Evacuate the area if exposed.
6. Use only cylinders rated DOT4BA/4BW 400.
7. Never fill cylinders over 80% of total capacity.
8. Store cylinders in a cool area, out of direct sunlight.
9. Never heat cylinders above 125°F.
10. Never trap liquid R-410A in manifold sets, gauge lines or cylinders. R-410A expands significantly at warmer temperatures. Once a cylinder or line is full of liquid, any further rise in temperature will cause it to burst.

START UP (Continued)

IMPORTANT INSTALLER NOTE

For improved start up performance wash the indoor coil with a dish washing detergent.

HIGH & LOW PRESSURE SWITCH

All W**H wall mounted air conditioner series models are supplied with a remote reset for the high and low pressure switch. If tripped, this pressure switch may be reset by turning the thermostat off then back on again.

THREE PHASE SCROLL COMPRESSOR START UP INFORMATION

Scroll compressors, like several other types of compressors, will only compress in one rotational direction. Direction of rotation is not an issue with single phase compressors since they will always start and run in the proper direction.

However, three phase compressors will rotate in either direction depending upon phasing of the power. Since there is a 50-50 chance of connecting power in such a way as to cause rotation in the reverse direction, verification of proper rotation must be made.

Verification of proper rotation direction is made by observing that suction pressure drops and discharge pressure rises when the compressor is energized. Reverse rotation also results in an elevated sound level over that with correct rotation, as well as substantially reduced current draw compared to tabulated values.

Verification of *proper rotation* must be made at the time the equipment is put into service. If improper rotation is corrected at this time, there will be no negative impact on the durability of the compressor. However, reverse operation for over one hour may have a negative impact on the bearing due to oil pump out.

NOTE: If compressor is allowed to run in reverse rotation for several minutes, the compressor's internal protector will trip.

All three phase ZP compressors are wired identically internally. As a result, once the correct phasing is determined for a specific system or installation, connecting properly phased power leads to the same Fusite terminal should maintain proper rotation direction.

The direction of rotation of the compressor may be changed by reversing any two line connections to the unit.

PHASE MONITOR

All units with three phase scroll compressors are equipped with a 3 phase line monitor to prevent compressor damage due to phase reversal.

The phase monitor in this unit is equipped with two LEDs. If the Y signal is present at the phase monitor and phases are correct the green LED will light.

If phases are reversed, the red fault LED will be lit and compressor operation is inhibited.

If a fault condition occurs, reverse two of the supply leads to the unit. ***Do not reverse any of the unit factory wires as damage may occur.***

CONDENSER FAN OPERATION

Applies to W42, W48 and W60 models only. The condenser fan motor on 230/208 volt, one and three phase, 60 HZ units is a two-speed motor that comes factory wired on high speed for peak performance. If ambient conditions permit, it can be reconnected to low speed (red wire) for lower sound level. See wiring diagram.

50 HZ models must have fan wired on low speed. These models are factory wired on low speed.

SERVICE HINTS

1. Caution owner/operator to maintain clean air filters at all times. Also, not to needlessly close off supply and return air registers. This reduces airflow through the system, which shortens equipment service life as well as increasing operating costs.
2. Check all power fuses or circuit breakers to be sure they are the correct rating.
3. Periodic cleaning of the outdoor coil to permit full and unrestricted airflow circulation is essential.

SEQUENCE OF OPERATION

COOLING – Circuit R-Y makes at thermostat pulling in compressor contactor, starting the compressor and outdoor motor. The G (indoor motor) circuit is automatically completed on any call for cooling operation or can be energized by manual fan switch on subbase for constant air circulation.

HEATING – A 24V solenoid coil on reversing valve controls heating cycle operation. Two thermostat options, one allowing “Auto” changeover from cycle to cycle and the other constantly energizing solenoid coil during heating season, and thus eliminating pressure equalization noise except during defrost, are to be used. On “Auto” option a circuit is completed from R-W1 and R-Y on each heating “on” cycle, energizing reversing valve solenoid and pulling in compressor contactor starting compressor and outdoor motor. R-G also make starting indoor blower motor. Heat pump heating cycle now in operation. The second option has no “Auto” changeover position, but instead energizes the reversing valve solenoid constantly whenever the system switch on subbase is placed in “Heat” position, the “B” terminal being constantly energized from R. A Thermostat demand for heat completes R-Y circuit, pulling in compressor contactor starting compressor and outdoor motor. R-G also make starting indoor blower motor.

PRESSURE SERVICE PORTS

High and low pressure service ports are installed on all units so that the system operating pressures can be observed. Pressure tables can be found later in the manual covering all models. It is imperative to match the correct pressure table to the unit by model number. See Tables 3A & 3B.

DEFROST CYCLE

The defrost cycle is controlled by temperature and time on the solid state heat pump control.

When the outdoor temperature is in the lower 40°F temperature range or colder, the outdoor coil temperature is 32°F or below. This coil temperature is sensed by the coil temperature sensor mounted near the bottom of the outdoor coil. Once coil temperature reaches 30°F or below, the coil temperature sensor sends a signal to the control logic of the heat pump control and the defrost timer will start accumulating run time.

After 30, 60 or 90 minutes of heat pump operation at 30°F or below, the heat pump control will place the system in the defrost mode.

During the defrost mode, the refrigerant cycle switches back to the cooling cycle, the outdoor motor stops, electric heaters are energized, and hot gas passing through the outdoor coil melts any accumulated frost. When the temperature rises to approximately 57°F, the coil temperature sensor will send a signal to the heat pump control which will return the system to heating operations automatically.

If some abnormal or temporary condition such as a high wind causes the heat pump to have a prolonged defrost cycle, the heat pump control will restore the system to heating operation automatically after 8 minutes.

The heat pump defrost control board has an option of 30, 60 or 90-minute setting. By default, this unit is shipped from the factory with the defrost time on the 60 minute pin. If circumstances require a change to another time, remove the

wire from the 60-minute terminal and reconnect to the desired terminal. Refer to Figure 8.

There is a cycle speed up jumper on the control. This can be used for testing purposes to reduce the time between defrost cycle operation without waiting for time to elapse.

Use a small screwdriver or other metallic object, or another ¼ inch QC, to short between the *SPEEDUP* terminals to accelerate the HPC timer and initiate defrost.

Be careful not to touch any other terminals with the instrument used to short the *SPEEDUP* terminals. It may take up to 10 seconds with the *SPEEDUP* terminals shorted for the speedup to be completed and the defrost cycle to start.

As soon as the defrost cycle kicks in remove the shorting instrument from the SPEEDUP terminals. Otherwise the timing will remain accelerated and run through the 1-minute minimum defrost length sequence in a matter of seconds and will automatically terminate the defrost sequence.

There is an initiate defrost jumper (sen jump) on the control that can be used at any outdoor ambient during the heating cycle to simulate a 0° coil temperature.

This can be used to check defrost operation of the unit without waiting for the outdoor ambient to fall into the defrost region. By placing a jumper across the *SEN JMP* terminals (a ¼ inch QC terminal works best) the defrost sensor mounted on the outdoor coil is shunted out & will activate the timing circuit. This permits the defrost cycle to be checked out in warmer weather conditions without the outdoor temperature having to fall into the defrost region.

In order to terminate the defrost test the *SEN JMP* jumper must be removed. If left in place too long, the compressor could stop due to the high pressure control opening because of high pressure condition created by operating in the cooling mode with outdoor fan off. Pressure will rise fairly fast as there is likely no actual frost on the outdoor coil in this artificial test condition.

There is also a 5-minute compressor time delay function built into the HPC. This is to protect the compressor from short cycling conditions. The board's LED will have a fast blink rate when in the compressor time delay. In some instances, it is helpful to the service technician to override or speed up this timing period, and shorting out the *SPEEDUP* terminals for a few seconds can do this.

Low Pressure Switch Bypass Operation - The control has a selectable (SW1) low pressure switch bypass set up to ignore the low pressure switch input during the first (30, 60, 120 or 180 seconds) of “Y” operation.

After this period expires, the control will then monitor the low pressure switch input normally to make sure that the switch is closed during “Y” operation.

High Pressure Switch Operation - The control has a built-in lockout system that allows the unit to have the high pressure switch trip up to two times in one hour and only encounter a “soft” lockout. A “soft” lockout shuts the compressor off and waits for the pressure switch to reset, which at that point then allows the compressor to be restarted as long as the 5-minute short cycle timer has run out. If the high pressure switch trips a third time within one hour, the unit is in “hard” lockout indicating something is certainly wrong and it will not restart itself.

**FIGURE 8
DEFROST CONTROL BOARD**

SW 1	SW 2	TIME (SEC)
OFF	OFF	30
ON	OFF	60
OFF	ON	120*
ON	ON	180

LOW PRESSURE BYPASS TIMER SWITCH
*(FACTORY SETTING 120 SECONDS)

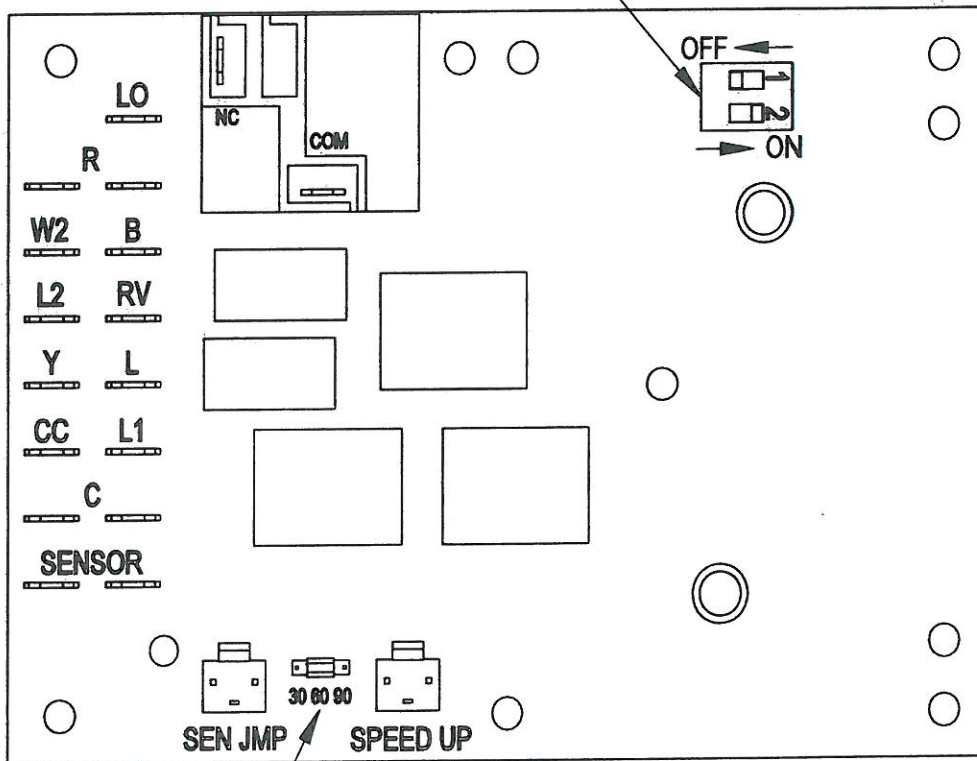

ACCUMULATED DEFROST TIME TIMER
(FACTORY SETTING 60 MIN.)

MIS-2668 A

TROUBLESHOOTING

SOLID STATE HEAT PUMP CONTROL TROUBLESHOOTING PROCEDURE

- NOTE:** A thorough understanding of the defrost cycle sequence is essential. Review that section earlier in this manual prior to troubleshooting the control. Turn on AC power supply to unit.
- Turn thermostat blower switch to "fan on" – the indoor blower should start. (If it doesn't, troubleshoot indoor unit and correct problem.)
- Turn thermostat blower to "auto" position. Indoor blower should stop. **NOTE:** Many models have a 1-minute blower time delay on "off" command; wait for this to time-out.
- Set system switch to "heat" or "cool". Adjust thermostat to call for heat or cool. The indoor blower, compressor and outdoor fan should start.

NOTE: If there was no power to 24 volt transformer, the compressor and outdoor fan motor will not start for 5 minutes. This is because of the compressor short cycle protection.

LED BLINK CODES

BLINK	FUNCTION
Slow	Normal function (1.0 sec on/1.0 sec off)
Fast	ASCD timer active (0.1 sec on/0.1 sec off)
1	Low pressure switch failure
2	High pressure switch failure/"Soft" Lockout
3	Defrost mode active
4	High pressure switch failure/"Hard" Lockout

**TABLE 1
TROUBLESHOOTING**

Symptom	Description, Check & Possible Causes	What & How to Check / Repair
Compressor will not start (heating or cooling)	1. Check for LED illumination. Is there an LED illuminated on the board (flashing)?	Yes = go to Step #2; No = go to Step #3
	2. Check for error codes. Is the LED flashing a Code?	Yes = go to Step #4; No = go to Step #8
	3. Check for power at board. Is there 24 volts AC between R and C?	Yes = go to Step #13; No = go to Step #9
	4. Check codes. What code is blinking?	Code "1", go to Step #6; Code "2", go to Step #7; Fast Blink, go to Step #5
	5. Compressor delay active. Wait for 5 minute delay or jump board's "speed up pins".	Check for proper operation; if still needed, go back to Step #1.
	6. Low pressure fault.	Check wiring circuit and unit pressures.
	7. High pressure fault.	Check wiring circuit and unit pressures.
	8. Check for Compressor input signal. Is there 24 volts AC between Y and C?	Yes = go to Step #10; No = go to Step #11
	9. No power to board.	The unit either does not have unit voltage, the transformer is bad or the unit wiring is incorrect.
	10. Check for Compressor output signal. Is there 24 volts AC between CC & C?	Yes = go to Step #12; No = go to Step #13
	11. No "Y" compressor input signal.	Check thermostat wiring, incorrect phase of unit (see section on Phase Monitor), and finally unit wiring.
	12. No "CC" compressor output signal.	Check compressor contactor for proper operation and finally check compressor.
	13. Faulty board.	Replace defrost board.
Fan outdoor motor does not run (cooling or heating except during defrost)	Heat pump control defective	Check across fan relay on heat pump control. (Com-NC) Replace heat pump control.
	Motor defective	Check for open or shorted motor winding. Replace motor.
	Motor capacitor defective	Check capacitor rating. Check for open or shorted capacitor. Replace capacitor.
Reversing valve does not energize (heating only)	Heat pump control defective	Check for 24V between RV-C and B-C. 1. Check control circuit wiring. 2. Replace heat pump control
	Reversing valve solenoid coil defective	Check for open or shorted coil. Replace solenoid coil.
Unit will not go into defrost (heating only)	Temperature sensor or heat pump control defective	Disconnect temperature sensor from board and jumper across "SPEEDUP" terminals and "SEN JMP" terminals. This should cause the unit to go through a defrost cycle within one minute. 1. If unit goes through defrost cycle, replace temperature sensor. 2. If unit does not go through defrost cycle, replace heat pump control.
Unit will not come out of defrost (heating only)	Temperature sensor or heat pump control defective	Jumper across "SPEEDUP" terminal. This should cause the unit to come out of defrost within one minute. 1. If unit comes out of defrost cycle, replace temperature sensor. 2. If unit does not come out of defrost cycle, replace heat pump control.

CHECKING TEMPERATURE SENSOR OUTSIDE UNIT CIRCUIT

1. Disconnect temperature sensor from board and from outdoor coil.
2. Use an ohmmeter and measure the resistance of the sensor. Also use ohmmeter to check for short or open.
3. Check resistance reading to chart of resistance. Use sensor ambient temperature. (Tolerance of part is $\pm 10\%$.)
4. If sensor resistance reads very low, then sensor is shorted and will not allow proper operation of the heat pump control.
5. If sensor is out of tolerance, shorted, open or reads very low ohms then it should be replaced.

TEMPERATURE F VS. RESISTANCE R OF TEMPERATURE SENSOR

F	R	F	R	F	R	F	R
-25.0	196871	13.0	56985	53.0	19374	89.0	7507
-24.0	190099	14.0	55284	52.0	18867	90.0	7334
-23.0	183585	15.0	53640	53.0	18375	91.0	7165
-22.0	177318	16.0	52051	54.0	17989	92.0	7000
-21.0	171289	17.0	50514	55.0	17434	93.0	6840
-20.0	165487	18.0	49028	56.0	16984	94.0	6683
-19.0	159904	19.0	47590	57.0	16547	95.0	6531
-18.0	154529	20.0	46200	58.0	16122	96.0	6383
-17.0	149355	21.0	44855	59.0	15710	97.0	6239
-16.0	144374	22.0	43554	60.0	15310	98.0	6098
-15.0	139576	23.0	42295	61.0	14921	99.0	5961
-14.0	134956	24.0	41077	62.0	14544	100.0	5827
-13.0	130506	25.0	39898	63.0	14177	101.0	5697
-12.0	126219	26.0	38757	64.0	13820	102.0	5570
-11.0	122089	27.0	37652	65.0	13474	103.0	5446
-10.0	118108	28.0	36583	66.0	13137	104.0	5326
-9.0	114272	29.0	35548	67.0	12810	105.0	5208
-8.0	110575	30.0	34545	68.0	12492	106.0	5094
-7.0	107010	31.0	33574	69.0	12183	107.0	4982
-6.0	103574	32.0	32634	70.0	11883	108.0	4873
-5.0	100260	33.0	31723	71.0	11591	109.0	4767
-4.0	97064	34.0	30840	72.0	11307	110.0	4663
-3.0	93981	35.0	29986	73.0	11031	111.0	4562
-2.0	91008	36.0	29157	74.0	10762	112.0	4464
-1.0	88139	37.0	28355	75.0	10501	113.0	4367
0.0	85371	38.0	27577	76.0	10247	114.0	4274
1.0	82699	39.0	26823	77.0	10000	115.0	4182
2.0	80121	40.0	26092	78.0	9760	116.0	4093
3.0	77632	41.0	25383	79.0	9526	117.0	4006
4.0	75230	42.0	24696	80.0	9299	118.0	3921
5.0	72910	43.0	24030	81.0	9077	119.0	3838
6.0	70670	44.0	23384	82.0	8862	120.0	3757
7.0	68507	45.0	22758	83.0	8653	121.0	3678
8.0	66418	46.0	22150	84.0	8449	122.0	3601
9.0	64399	47.0	21561	85.0	8250	123.0	3526
10.0	62449	48.0	20989	86.0	8057	124.0	3452
11.0	60565	49.0	20435	87.0	7869		
12.0	58745	50.0	19896	88.0	7686		

TROUBLESHOOTING

FAN BLADE SETTING DIMENSIONS

Shown in Figure 9 is the correct fan blade setting for proper air delivery across the outdoor coil. Refer to Table 2 for unit specific dimension.

Any service work requiring removal or adjustment in the fan and/or motor area will require that the dimensions below be checked and blade adjusted in or out on the motor shaft accordingly.

**FIGURE 9
FAN BLADE SETTING**

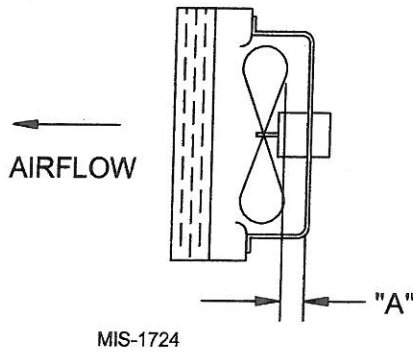

**TABLE 2
FAN BLADE DIMENSION**

Model	Dimension A
W18H1 W24H1	1.00"
W30H1 W36H1	1.25"
W42H1 W48H1 W60H1	1.75"

REMOVAL OF FAN SHROUD

1. Disconnect all power to the unit.
2. Remove the screws holding both grilles, one on each side of unit, and remove grilles.
3. Remove screws holding fan shroud to condenser and bottom. Nine (9) screws.
4. Unwire condenser fan motor.
5. Slide complete motor, fan blade, and shroud assembly out the left side of the unit.
6. Service motor/fan as needed.
7. Reverse steps to reinstall.

R-410A

REFRIGERANT CHARGE

This unit was charged at the factory with the quantity of refrigerant listed on the serial plate. AHRI capacity and efficiency ratings were determined by testing with this refrigerant charge quantity.

The following pressure tables show nominal pressures for the units. Since many installation specific situations can affect the pressure readings, this information should only be used by certified technicians as a guide for evaluating proper system performance. They shall not be used to adjust charge. If charge is in doubt, reclaim, evacuate and recharge the unit to the serial plate charge.

**TABLE 3A
COOLING PRESSURE TABLE**

Air Temperature Entering Outdoor Coil °F

Model	Return Air Temperature	Pressure	75	80	85	90	95	100	105	110	115	120
W18H1	75 deg. DB 62 deg. WB	Low Side	132	134	137	138	140	142	144	146	148	150
		High Side	292	311	332	353	376	400	424	450	477	505
	80 deg. DB 67 deg. WB	Low Side	141	143	146	148	150	152	154	156	158	160
		High Side	299	319	340	362	386	410	435	462	489	518
	85 deg. DB 72 deg. WB	Low Side	146	148	151	153	155	157	159	161	164	166
		High Side	309	330	352	375	400	424	450	478	506	536
W24H1	75 deg. DB 62 deg. WB	Low Side	124	126	128	131	133	135	137	138	140	142
		High Side	329	351	373	398	423	449	475	503	531	561
	80 deg. DB 67 deg. WB	Low Side	133	135	137	140	142	144	146	148	150	152
		High Side	337	360	383	408	434	460	487	516	545	575
	85 deg. DB 72 deg. WB	Low Side	138	140	142	145	147	149	151	153	155	157
		High Side	349	373	396	422	449	476	504	534	564	595
W30H1	75 deg. DB 62 deg. WB	Low Side	125	128	131	133	136	137	139	141	143	145
		High Side	326	350	373	398	423	448	472	496	522	547
	80 deg. DB 67 deg. WB	Low Side	134	137	140	142	144	147	149	151	153	155
		High Side	334	359	383	408	438	469	484	509	535	561
	85 deg. DB 72 deg. WB	Low Side	139	142	145	147	150	152	154	156	158	160
		High Side	346	372	396	422	449	475	501	527	554	581
W36H1	75 deg. DB 62 deg. WB	Low Side	122	124	126	128	130	132	135	137	138	141
		High Side	329	351	375	399	424	449	476	503	530	559
	80 deg. DB 67 deg. WB	Low Side	131	133	135	137	137	141	144	146	148	151
		High Side	337	360	385	409	444	461	488	516	544	573
	85 deg. DB 72 deg. WB	Low Side	136	138	140	142	144	146	149	151	153	156
		High Side	349	373	398	423	450	477	505	534	563	593
W42H1	75 deg. DB 62 deg. WB	Low Side	127	130	132	134	135	136	137	137	137	136
		High Side	354	372	392	413	437	461	488	516	546	578
	80 deg. DB 67 deg. WB	Low Side	136	139	141	143	143	145	146	146	146	145
		High Side	363	382	402	424	452	473	500	529	560	593
	85 deg. DB 72 deg. WB	Low Side	141	144	146	148	149	150	151	151	151	150
		High Side	376	395	416	439	464	490	518	548	580	614
W48H1	75 deg. DB 62 deg. WB	Low Side	129	132	134	136	137	139	141	143	145	146
		High Side	352	374	398	422	449	476	505	535	566	600
	80 deg. DB 67 deg. WB	Low Side	138	141	143	145	147	149	151	153	155	156
		High Side	361	384	408	433	460	488	518	549	581	615
	85 deg. DB 72 deg. WB	Low Side	143	146	148	150	152	154	156	158	160	161
		High Side	374	397	422	448	476	505	536	568	601	637
W60H1	75 deg. DB 62 deg. WB	Low Side	126	128	131	133	135	137	139	141	143	145
		High Side	332	352	373	397	421	448	476	505	536	568
	80 deg. DB 67 deg. WB	Low Side	135	137	140	142	143	147	149	151	153	155
		High Side	341	361	383	407	434	459	488	518	550	583
	85 deg. DB 72 deg. WB	Low Side	140	142	145	147	149	152	154	156	158	160
		High Side	353	374	396	421	447	475	505	536	569	603

Low side pressure ± 4 PSIG

High side pressure ± 10 PSIG

Tables are based upon rated CFM (airflow) across the evaporator coil. If there is any doubt as to correct operating charge being in the system, the charge should be removed, system evacuated and recharged to serial plate charge weight.

NOTE: Pressure table based on high speed condenser fan operation. If condensing pressures appear elevated check condenser fan wiring. See "Condenser Fan Operation".

**TABLE 3B
HEATING PRESSURES – (ALL TEMPERATURES °F)**

Model	Return Air Temperature	Pressure	0	5	10	15	20	25	30	35	40	45	50	55	60
W18H	70 deg.	Low Side	48	52	56	61	66	72	79	87	95	104	114	124	135
		High Side	290	285	282	282	285	290	297	307	319	334	352	372	394
W24H	70 deg.	Low Side	57	55	55	57	59	64	70	77	86	96	108	121	135
		High Side	292	296	301	307	314	323	332	342	354	367	380	395	411
W30H	70 deg.	Low Side	53	53	55	58	61	66	72	80	88	97	108	119	132
		High Side	254	266	278	290	301	312	322	332	342	351	360	369	377
W36H	70 deg.	Low Side	47	49	51	55	59	64	70	77	85	93	103	113	124
		High Side	281	282	283	287	292	300	308	319	331	345	361	379	398
W42H	70 deg.	Low Side	50	50	52	54	58	62	68	75	84	93	104	115	128
		High Side	299	300	303	308	314	322	331	342	355	370	386	404	423
W48H	70 deg.	Low Side	42	45	49	54	59	64	70	77	84	92	100	109	118
		High Side	268	270	274	278	284	291	298	307	317	327	339	352	366
W60H	70 deg.	Low Side	39	43	47	52	58	63	70	76	84	92	100	109	118
		High Side	294	296	300	305	311	319	328	338	349	362	376	391	408

TABLE 4

Electrical Specifications — WH Series**

Model	Rated Volts and Phase	No. Field Power Circuits	Single Circuit				Dual Circuit									
			⊙ Minimum Circuit Ampacity	⊙ Maximum External Fuse or Ckt. Brkr.	⊙ Field Power Wire Size	⊙ Ground Wire	⊙ Minimum Circuit Ampacity		⊙ Maximum External Fuse or Ckt. Breaker		⊙ Field Power Wire Size		⊙ Ground Wire Size			
							Ckt. A	Ckt. B	Ckt. A	Ckt. B	Ckt. A	Ckt. B	Ckt. A	Ckt. B		
W18H1- A00, A0Z A04 ⊙ A08	230/208-1	1 1 1	16 37 58	20 40 60	12 8 6	12 10 10										
W24H1- A00, A0Z A04 ⊙ A08	230/208-1	1 1 1	24 44 65	25 50 70	10 8 6	10 10 8	44	21	45	25	8	10	10	10		
W24H1- B00, B0Z B06	230/208-3	1 1	17 35	20 40	12 8	12 10										
W24H1- C00, C0Z C06	460-3	1 1	11 21	15 25	14 10	14 10										
W30H1- A00, A0Z* A05* ⊙ A10*	230/208-1	1 1 1 or 2	24 50 76	35 50 80	8 8 4	10 10 8	50	26	50	30	8	10	10	10		
W30H1- B00, B0Z* B06 ⊙ B09* ⊙ B09*	230/208-3	1 1 1 1	18 36 45	25 40 45	10 8 8	10 10 10										
W30H1- C00, C0Z* C06 ⊙ C09* C15	460-3	1 1 1 1	11 20 25 26	15 20 25 30	14 12 10 10	14 12 10 10										
W36H1- A00, A0Z* A05 ⊙ A10* ⊙ A15	230/208-1	1 1 1 or 2 1 or 2	29 55 81 84	40 60 90 90	8 6 4 4	10 10 8 8	55	26	60	30	6	10	10	10	10	
W36H1- B00, B0Z* B06 ⊙ B09* ⊙ B15	230/208-3	1 1 1 1	23 41 50 51	30 45 50 60	10 8 8 8	10 10 10 10										
W36H1- C00, C0Z* C06 ⊙ C09* C15	460-3	1 1 1 1	12 21 25 26	15 25 25 30	14 10 10 10	14 10 10 10										
W42H1- A00, A0Z A05 ⊙ A10 ⊙ A15	230/208-1	1 1 1 or 2 1 or 2	36 62 88 88	50 70 90 90	8 6 3 3	10 8 8 8	36	26	50	30	8	10	10	10	10	
W42H1- B00, B0Z B06 ⊙ B09 ⊙ B15	230/208-3	1 1 1 1	26 44 53 53	35 50 60 60	8 8 6 6	10 10 10 10										
W42H1- C00, C0Z C06 ⊙ C09 ⊙ C15	460-3	1 1 1 1	13 22 26 26	15 25 30 30	14 10 10 10	14 10 10 10										
W48H1- A00, A0Z A04 A05 ⊙ A10 ⊙ A15 ⊙ A20	230/208-1	1 1 1 or 2 1 or 2 1 or 2 1 or 2	37 58 63 89 89 111	50 60 70 90 90 125	8 6 6 3 3 2	10 10 8 8 8 6	37	26	50	30	8	10	10	10	10	
W48H1- B00, B0Z B06 ⊙ B09 ⊙ B15 ⊙ B18	230/208-3	1 1 1 1 1 or 2	29 47 56 56 62	35 50 60 60 70	8 8 6 6 6	10 10 10 10 8	34	28	40	30	8	10	10	10	10	
W48H1- C00, C0Z ⊙ C09 ⊙ C15	460-3	1 1 1	14 27 27	20 30 30	12 10 10	12 10 10										
W60H1- A00, A0Z A05 ⊙ A10 ⊙ A15 ⊙ A20	230/208-1	1 1 or 2 1 or 2 1 or 2 1 or 2	41 67 93 93 111	60 80 100 100 125	8 4 3 3 2	10 8 8 8 6	41	26	60	30	8	10	10	10	10	
W60H1- B00, B0Z ⊙ B09 ⊙ B15 ⊙ B18	230/208-3	1 1 1 1	28 55 55 62	40 60 60 70	8 6 6 6	10 10 10 10	34	28	40	30	8	10	10	10	10	
W60H1- C00, C0Z ⊙ C09 ⊙ C15	460-3	1 1 1	16 28 28	20 30 30	12 10 10	12 10 10										

- ⊙ Maximum size of the time delay fuse or HACR type circuit breaker for protection of field wiring conductors.
- ⊙ Based on 75C copper wire. All wiring must conform to the National Electrical Code and all local codes.
- ⊙ These "Minimum Circuit Ampacity" values are to be used for sizing the field power conductors. Refer to the National Electrical code (latest version), Article 310 for power conductor sizing.

Caution: When more than one field power circuit is run through one conduit, the conductors must be derated. Pay special attention to note 8 of Table 310 regarding Ampacity Adjustment Factors when more than three (3) current carrying conductors are in a raceway.

* Top outlet supply option is available only factory installed and only on the selected models.

IMPORTANT: While this electrical data is presented as a guide, it is important to electrically connect properly sized fuses and conductor wires in accordance with the National Electrical Code and all local codes.

**TABLE 5
RECOMMENDED AIRFLOW**

Model	Rated CFM *	Rated ESP *	Recommended Airflow Range	Factory Speed Connection
W18H	600 Ⓣ	.30	575 - 725	High
W24H	800	.20	700 - 950	High
W30H	1000	.40	930 - 1300	High
W36H	1100	.30	930 - 1350	High
W42H	1400	.30	1600 - 1150	High
W48H	1550	.20	1750 - 1285	High
W60H	1650	.30	1950 - 1375	High

* Rated CFM and ESP on high speed tap.

Ⓣ Rated CFM and ESP on low speed tap.

**TABLE 6
INDOOR BLOWER PERFORMANCE**

E.S.P. In H ₂ O	W18H, W24H		W18H		W30H, W36H				W42H, W48H				W60H			
	High Speed		Low Speed		High Speed		Low Speed		High Speed		Low Speed		High Speed		Low Speed	
	Dry Coil	Wet Coil	Dry Coil	Wet Coil	Dry Coil	Wet Coil	Dry Coil	Wet Coil	Dry Coil	Wet Coil	Dry Coil	Wet Coil	Dry Coil	Wet Coil	Dry Coil	Wet Coil
.0	1020	975	750	700	1395	1315	950	935	1885	1800	1650	1600	2200	2000	1600	1450
.1	960	905	735	675	1340	1270	930	915	1770	1665	1550	1500	2100	1900	1525	1375
.2	865	800	710	650	1285	1190	910	885	1635	1540	1450	1400	2000	1800	—	—
.3	820	735	660	600	1205	1100	855	830	1500	1400	1350	1300	1875	1700	—	—
.4	735	650	605	550	1110	1000	800	755	1370	1285	1300	1175	1775	1600	—	—
.5	615	535	540	490	1005	870	—	—	1250	1150	—	—	1650	1475	—	—

**TABLES 7
MAXIMUM ESP OF OPERATION
ELECTRIC HEAT ONLY**

Model	ESP
W18H1 A00	.50
W24H1 A04	.50
W24H1 A08	.40
W24H1 B00	.50
W24H1 B06	.50
W24H1 C00	.50
W24H1 C06	.50

Model	Front Outlet		Top Outlet	
	Low Speed	High Speed	Low Speed	High Speed
W30H1 A00	.50	.50	.50	.50
W30H1 A05	.40	.50	.40	.50
W36H1 A10	.35	.40	.25	.40
W36H1 A15	.35	.40	NA	NA
W30H1 B00	.50	.50	.50	.50
W30H1 B06	.40	.50	NA	NA
W36H1 B09	.35	.45	.30	.40
W36H1 B15	.35	.45	NA	NA
W30H1 C00	.50	.50	.50	.50
W30H1 C06	.50	.50	NA	NA
W36H1 C09	.30	.40	.35	.45
W36H1 C15	.30	.40	NA	NA

Model Speed KW	W42H1		W48H1		W60H1	
	High Speed	Low Speed	High Speed	Low Speed	High Speed	Low Speed
-A00	.50	.50	.50	.50	.50	.40
-A04	---	---	.50	.50	---	---
-A05	.50	.50	.50	.50	.50	.25
-A10	.50	.45	.50	.45	.50	.25
-A15	.50	.45	.50	.45	.50	.25
-A20	---	---	.50	.45	.50	.25
-B00	.50	.50	.50	.50	.50	.40
-B09	.50	.45	.50	.45	.50	.30
-B15	.50	.45	.50	.45	.50	.30
-B18	---	---	.50	.45	.50	.30
-C00	.50	.50	.50	.50	.50	.40
-C09	.50	.40	.50	.40	.50	.35
-C15	.50	.40	.50	.40	.50	.35

**TABLE 8
ELECTRIC HEAT**

Models	240V-1		208V-1		240V-3		208V-3		460V-3		
	KW	Amps	BTUH	Amps	BTUH	Amps	BTUH	Amps	BTUH	Amps	BTUH
4	16.7	13650	14.4	10240							
5	20.8	17065	18.1	12800							
6					14.4	20500	12.5	15360	7.2	20500	
8	33.3	27300	28.8	20475							
9					21.7	30600	18.7	23030	10.8	30700	
10	41.6	34130	36.2	25600							
12									14.4	40950	
15	62.5	51250	54.0	38400	36.2	51200	31.2	38400	18.0	51200	
18					43.3	61430	37.5	46100			
20	83.2	68260	72.1	51200							

**TABLE 9
OPTIONAL ACCESSORIES**

Part Number	W18H1-A	W24H1-A	W24H1-B	W24H1-C	W30H1-A	W30H1-B	W30H1-C	W36H1-A	W36H1-B	W36H1-C	W42H1-A	W42H1-B	W42H1-C	W48H1-A	W48H1-B	W48H1-C	W60H1-A	W60H1-B	W60H1-C		
HEATER KITS	EHWH02A-A04	X																			
	EHWH02A-A08	X																			
	EHW24H-A04		X																		
	EHW24H-A08		X																		
	EHW24H-B06				X																
	EHWH30-A05					X															
	EHWH30-A10					X															
	EHWH36-A05								X												
	EHWH36-A10								X												
	EHWH36-A15								X												
	EHWH03-B06						X														
	EHW36H-B06									X											
	EHWH03-B09						X			X											
	EHW30H-B15									X											
	EHWC03A-C06							X			X										
	EHWH42-A05											X			X						
	EHWH42-A10											X			X						
	EHWH42-A15											X			X						
	EHWH04-A20														X			X			
	EHWH05-B06												X			X					
	EHWH05-B09												X			X			X		
	EHWH05-B15												X			X			X		
	EHWH42-C06													X							
	EHWH05A-C09														X		X			X	
	EHWH05A-C15														X		X			X	
	EHWH04-A15																	X			
	EHWH04-A10																	X			
	EHW05H-B18															X			X		
	CIRCUIT BREAKER (WMCB) & PULL DISCONNECT (WMPD)	WMCB-02A	X																		
		WMCB-02B			X																
WMCB-03A			X																		
WMCB-03B						X			X												
WMCB-06A						X		X													
WMCB-05B											X				X						
WMCB-07B																		X			
WMCB-08A											X			X							
WMCB-09A																	X				
WMPD-01C					X		X			X			X			X				X	

**TABLE 10
VENT & CONTROL OPTIONS**

Part Number	Description	W18, W24	W30, W36	W42, W48, W60
CMC-14	ODT	X	X	X
CMC-15	Start Kit (230V 1-Phase only) ①	X	X	X
SK111	Start Kit (230V 1-Phase only) ②	X	X	X
CMC-28	LAC	X	X	X
BFAD-2	Barometric Fresh Air Damper - Standard	X		
BOP-2	Blank Off Plate	X		
MFAD-2	Motorized Fresh Air Damper	X		
CRV-2	Commercial Ventilator - Spring Return	X		
EIFM-2B	Economizer	X		
ERVF-A2	Energy Recovery Ventilator - 230 Volt	X		
BFAD-3	Barometric Fresh Air Damper - Standard		X	
BOP-3	Blank Off Plate		X	
MFAD-3	Motorized Fresh Air Damper		X	
CRVS-3	Commercial Ventilator - Spring Return		X	
CRVP-3	Commercial Ventilator - Power Return		X	
EIFM-3C	Economizer		X	
ERVF-A3	Energy Recovery Ventilator - 230 Volt		X	
ERVF-C3	Energy Recovery Ventilator - 460 Volt		X	
BFAD-5	Barometric Fresh Air Damper - Standard			X
BOP-5	Blank Off Plate			X
MFAD-5	Motorized Fresh Air Damper			X
CRVS-5	Commercial Ventilator - Spring Return			X
CRVP-5	Commercial Ventilator - Power Return			X
EIFM-5C	Economizer			X
ERVF-A5	Energy Recovery Ventilator - 230 Volt			X
ERVF-C5	Energy Recovery Ventilator - 460 Volt			X

① PTCR Start Kit can be used with all -A single phase models. Increases starting torque 2-3x. Not used for -B or -C three phase models. Do not use if SK111 is used.

② Start Capacitor and potential relay start kit can be used with all -A single phase models. Increases starting torque 9x. Not used for -B or -C three phase models. Do not use if CMC-15 is used.

